



Z
G
E
T
S
Z
I

SwitchLinc™ V2 Dimmer - 1000W

INSTEON Dimmer Switch

For models:
#2476DH SwitchLinc V2 Dimmer 1000W



smartlabs
design

SwitchLinc V2 Dimmer 1000W User's Guide



TABLE OF CONTENTS

ABOUT SWITCHLINC DIMMER	4
What is INSTEON?.....	4
Key SwitchLinc Dimmer Features	4
HOW TO INSTALL SWITCHLINC DIMMER.....	5
Tools You Will Need	5
Preparing to Install SwitchLinc Dimmer.....	6
Installing SwitchLinc Dimmer	7
Installing SwitchLinc Dimmer in a Multi-Way Circuit	8
HOW TO SET UP SWITCHLINC DIMMER TO REMOTELY CONTROL AN INSTEON DEVICE	14
Linking SwitchLinc Dimmer to a Controlled INSTEON Device.....	14
Unlinking a Controlled INSTEON Device from SwitchLinc Dimmer.....	15
Creating an INSTEON Scene.....	15
HOW TO SET UP SWITCHLINC DIMMER TO BE REMOTELY CONTROLLED BY AN INSTEON CONTROLLER	16
Linking an INSTEON Controller to SwitchLinc Dimmer	16
Unlinking SwitchLinc Dimmer from an INSTEON Controller.....	17
HOW TO SET UP ON-LEVELS AND RAMP RATES.....	18
Setting the On-Level and Ramp Rates (Optional).....	18
Setting the On-Level.....	18
Setting the Ramp Rate	19
Locking In a Remote-Controlled On-Level and Ramp Rate.....	19
Locking In a Local On-Level and Ramp Rate.....	19
HOW TO CROSS-LINK MORE THAN ONE SWITCHLINC DIMMER.....	20
Cross-Linking in a 3-Way Circuit.....	20
ADVANCED FEATURES OF SWITCHLINC DIMMER.....	21
Restoring Power to SwitchLinc Dimmer	21
Resetting SwitchLinc Dimmer to Its Factory Default Settings.....	21
X10 PROGRAMMING OPTIONS	22
Setting the X10 Primary Address	22
Removing the X10 Primary Address	22
Setting the X10 On-Level and X10 Ramp Rate for the X10 Primary Address	23
Enabling and Disabling X10 Resume Dim	23
ADVANCED X10 PROGRAMMING OPTIONS.....	24
Remotely Setting the On-Level for the X10 Primary Address.....	24
Remotely Setting the Ramp Rate for the X10 Primary Address	24
About X10 Scene Address Programming.....	25
Remotely Setting an X10 Scene Address and On-Level	25
Remotely Removing an X10 Scene Address	25
Remotely Setting the Ramp Rate for an X10 Scene Address.....	26
HOW TO USE SWITCHLINC DIMMER.....	27
Using the Paddle	27
Using the Air Gap	27
COLOR OPTIONS FOR SWITCHLINC DIMMER.....	28

Paddle and LED Colors are Changeable	28
How to Change Paddle and LED Colors	28
ABOUT INSTEON	30
Understanding Why an INSTEON Network Is Reliable.....	30
Further Enhancing Reliability	30
Using Smarthome's Signalinc RF to Upgrade Your INSTEON Network	30
About INSTEON and X10.....	31
TROUBLESHOOTING.....	32
SPECIFICATIONS	34
SwitchLinc Dimmer Specifications	34
Certification.....	36
Limited Warranty	36

ABOUT SWITCHLINC DIMMER

Congratulations on purchasing the INSTEON™ SwitchLinc™ Dimmer 1000W. With its elegant look, smooth touch, and stylish LED Bar, you can not only control the lights that you wire it to, but you can add remote control to all kinds of other INSTEON and X10 devices in your home to match your lifestyle. Besides controlling other devices, SwitchLinc Dimmer can itself be remotely operated from other INSTEON or X10 Controllers, including other SwitchLinc Dimmers.

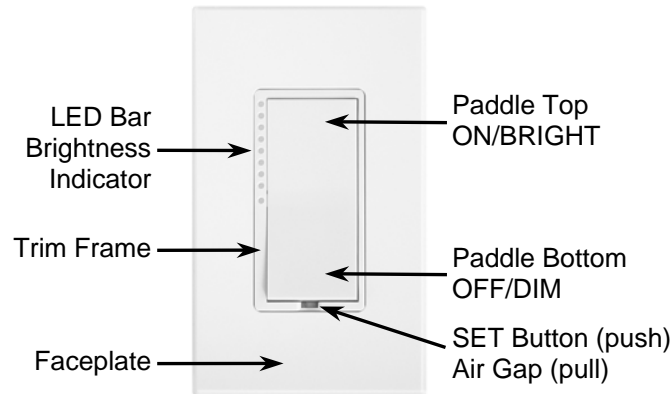

What is INSTEON?

INSTEON is a simple, reliable, and affordable breakthrough in home control. Simple, because Plug-n-Tap™ setup is a breeze, and there are no wires to add – INSTEON uses existing powerline wiring as well as radio-frequency for communication. Reliable, because every INSTEON device is a two-way repeater. And affordable, not just because of low cost, but because INSTEON also works with legacy X10 devices. An INSTEON home grows in value with every INSTEON device you add, making life more convenient, safe and fun.

Key SwitchLinc Dimmer Features

- After installation, setup is easy – links to controlled devices and other controllers in minutes
- Controls all standard incandescent lamps, up to 1000 watts
- Paddle has true rocker action – top is ON or BRIGHT, bottom is OFF or DIM
- 9-level LED Bar shows brightness of lights
- Dims lights to 32 brightness levels
- Changes brightness at 32 ramp rates
- Paddle and Trim Frame colors are changeable to ivory, almond, black, brown, or gray with optional kit (comes in white)
- White LED Bar color is changeable to green, blue, amber, or red with optional kit
- Responds to commands from X10 controllers and sends X10 commands to X10 devices
- Wires in like a standard wall switch (but also requires a NEUTRAL connection)
- Supports “virtual” 3-, 4-, or more-way circuits with multiple SwitchLinc Dimmers
- Warranted for two years

HOW TO INSTALL SWITCHLINC DIMMER

Caution

Read and understand these instructions before installing, and retain them for future reference.

SwitchLinc Dimmer is intended for installation in accordance with the National Electric Code and local regulations in the United States, or the Canadian Electrical Code and local regulations in Canada. Use indoors only. SwitchLinc Dimmer is not designed nor approved for use on power lines other than 120V 60Hz, single phase. Attempting to use SwitchLinc Dimmer on non-approved powerlines may have hazardous consequences.

Do not install SwitchLinc Dimmer to control a receptacle or fluorescent lighting fixture. Connect only copper or copper-clad wire to SwitchLinc Dimmer. Before installing, disconnect power at the circuit breaker or remove the circuit's fuse to avoid shock or possible damage to SwitchLinc Dimmer. It is recommended that a qualified electrician perform this installation.

To reduce the risk of overheating and possible damage to other equipment, use SwitchLinc Dimmer to control 110V incandescent lamps only. Dimming an inductive load, such as a fan or transformer, could cause damage to the dimmer, the load device, or both. If the manufacturer of the load device does not recommend dimming, use a non-dimming INSTEON switch such as SwitchLinc V2 Relay. **USER ASSUMES ALL RISKS ASSOCIATED WITH DIMMING AN INDUCTIVE LOAD.**



Proper installation of at least two SignalLinc™ RF Signal Enhancers is required prior to installing and using other INSTEON devices.

Tools You Will Need

- A flat screwdriver to remove the faceplate from the switch junction box.
- A Phillips screwdriver for the screws that hold SwitchLinc Dimmer in the junction box.
- A wire cutter and stripper if the switch you are replacing requires you to cut the wires to remove them.
- A small Phillips screwdriver if you will be changing the color of the trim frame and paddle.

A Helpful Tool – Voltmeter or Voltage Tester

During the installation of SwitchLinc Dimmer, it may be necessary to identify the wires inside the junction box. Knowing for sure which wire is the LINE (sometimes called HOT) can reduce the guesswork when installing a single switch, and it is absolutely necessary when working with multi-way lighting circuits. A voltmeter is ideal for this application. Many of the digital models can also read current so you can measure how much power is being drawn by the switch's load.

A simpler measurement tool, available at most home improvement centers, is a voltage sensor. This device, often costing less than \$20, can sense voltage when placed near a wire. The tip of the voltage sensor can tell if voltage is on the wire without touching the bare copper conductor or breaking the insulation.

When using these tools, be certain to read and understand the safety instructions. Often when these tools are used, the power to the circuit will need to be turned on. When working around live electrical wires, take your time and concentrate on the task.

Preparing to Install SwitchLinc Dimmer

IMPORTANT!

If you are not knowledgeable about and comfortable with electrical circuitry, you should have a qualified electrician install SwitchLinc Dimmer for you. Additionally, SwitchLinc Dimmer requires the presence of a neutral wire in the installation location. *Your will not be able to use SwitchLinc Dimmer without a neutral wire.* If there is no neutral wire available, or if you are unsure if you have a neutral wire, please contact SmartLabs Tech Support for information and assistance.

SmartLabs Tech Support
866-243-8018

Before installing SwitchLinc Dimmer, please familiarize yourself with the following and take the necessary precautions listed here:

- Be sure that you have turned off the circuit breaker or removed the fuse for the circuit you are installing SwitchLinc Dimmer in. Installing SwitchLinc Dimmer with the power on will expose you to dangerous voltages.
- SwitchLinc Dimmer requires a small amount of power to operate, which it receives from a connection to the NEUTRAL electrical wire (usually white). If you are replacing a standard mechanical switch with SwitchLinc Dimmer, the switch you are replacing will normally *not* have a connection to the neutral wire. However, most junction boxes will contain a NEUTRAL wire that you can connect SwitchLinc Dimmer to. If your junction box does not contain a neutral wire, please call SmartLabs Tech Support at 866-243-8018, or consult an electrician.
- Don't use SwitchLinc Dimmer to control low-voltage lighting with electronic transformers, fluorescent lights, or motors. These are inductive loads, which SwitchLinc Dimmer is not designed to control. Use a SmartLabs SwitchLinc V2 Relay instead.
- Don't use SwitchLinc Dimmer to control an electrical outlet, because non-dimmable or inductive loads may be plugged into it.
- SwitchLinc Dimmer may feel warm during operation. This includes the exaggerated mounting fins, which are designed to aid in heat dissipation. The amount of heat generated is within approved limits and poses no hazards. To minimize heat buildup, ensure that the area surrounding the rear of SwitchLinc Dimmer has adequate ventilation by clearing away excess insulation.
- If the dissipation fins prevent SwitchLinc Dimmer from fitting in the desired installation location, the fins can be removed by grasping the edge of each fin with pliers, and bending the fin back and forth along the score line until the fin breaks off. The removal of each individual fin reduces SwitchLinc Dimmer's rated capacity by 100W, since removing the fins reduce the heat dissipation capacity. Removing a single fin reduces SwitchLinc Dimmer's rating to 900W, removing two fins reduces capacity to 800W, and removing all four fins reduces capacity to 600W. Please note: dissipation fins cannot be reattached once removed.

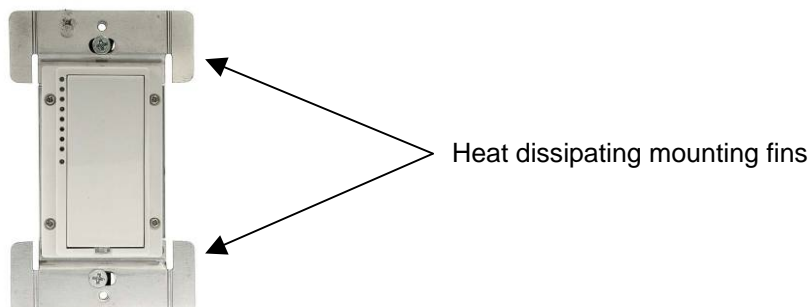

Installing SwitchLinc Dimmer

1. For best INSTEON Network performance, be sure you have properly installed at least two SignalLinc RF Signal Enhancers.
2. At the circuit breaker or fuse panel, disconnect the power for *all* of the circuits in the switch junction box. Verify that power is off by trying to turn on the lights controlled by the switches.
3. Remove the faceplate from the switch junction box, then unscrew the switch you are replacing and pull it out from the junction box.
4. Disconnect the wires from the switch you are replacing. If the wires cannot be detached by unscrewing them, cut the wires where they enter the switch, then strip ½" of insulation off the ends.
5. If you are installing SwitchLinc Dimmer into a standard **two-way circuit** (where only one switch controls the load), follow the diagram below to identify and connect the LINE, LOAD, NEUTRAL, and GROUND wires. If the colors of the wires do not match the diagram, be sure you have identified the wires correctly before connecting them.
6. If you are installing SwitchLinc Dimmer into a **multi-way circuit** (where more than one switch controls the same load), follow the instructions in the section *Installing SwitchLinc Dimmer in a Multi-Way Circuit*, below, to identify and connect the LINE, TRAVELER, NEUTRAL, and GROUND wires.

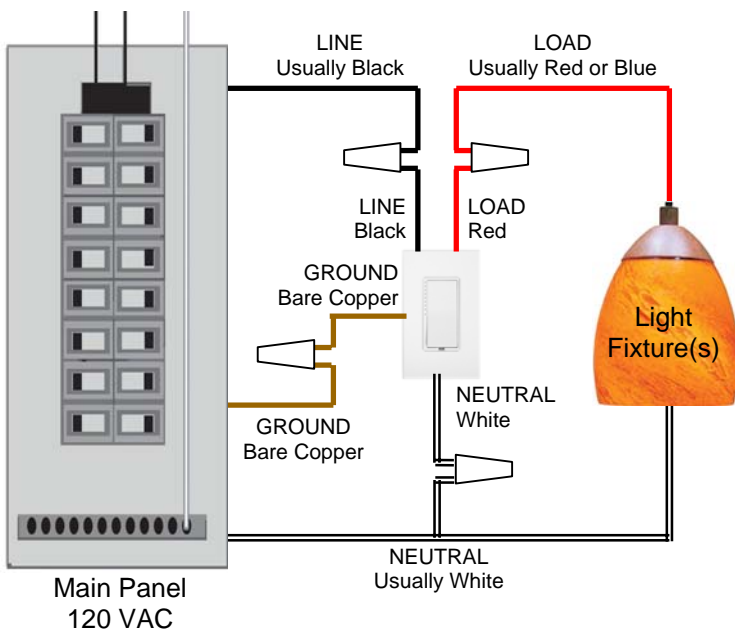

NOTE
The NEUTRAL wire will not normally be connected to the switch you are replacing. If there is no NEUTRAL wire in the junction box (SwitchLinc Dimmer *will not function* without a neutral), please consult an electrician or call
SmartLabs Tech Support
866-243-8018

7. After you have connected all of the wires, ensure that all of the wire connectors are firmly attached and that there is no exposed copper except for the GROUND wire.
8. Orient SwitchLinc Dimmer with the LED Bar at the left, gently place it into the junction box, then screw it into place.
9. Turn the circuit breaker back on or re-install the fuse.
10. After the bottom LED in the LED Bar comes on, test that SwitchLinc Dimmer is working properly by turning the light on and off.
11. Reinstall the faceplate.

Installing SwitchLinc Dimmer in a Multi-Way Circuit

Understanding Multi-Way Circuits

If more than one switch controls a single set of lights (called a LOAD), the switches are part of a multi-way circuit. A 3-way circuit uses two switches to control a LOAD, a 4-way circuit uses three switches, and so forth. Most homes have one or more 3-way circuits, with two switches located in hallways, stairwells, or two different entrances to a room. Less commonly found are circuits that are 4-way or above.

You can use SwitchLinc Dimmers to replace switches in multi-way circuits that are already wired in, or you can use them to *create virtual* multi-way circuits where there is no existing wiring.

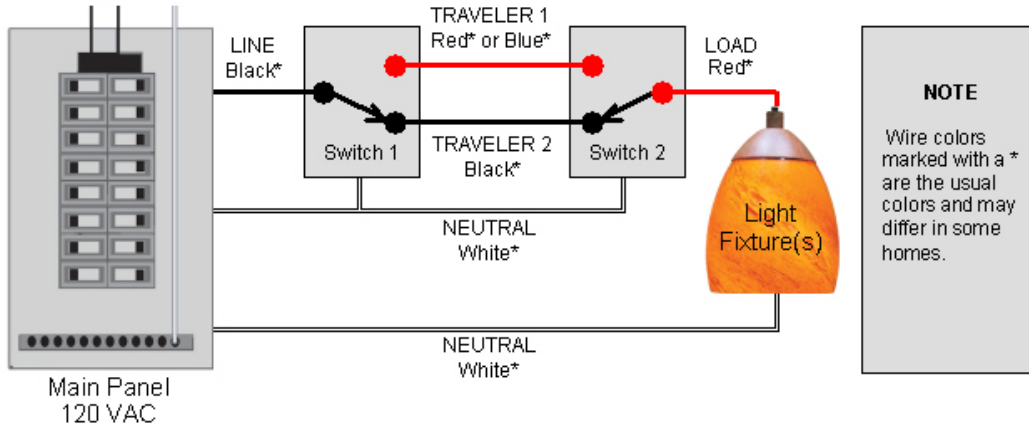

Here is how a wired-in three-way circuit (with two switches) works:

A wired-in four- or more-way circuit (with three or more switches) has additional switches added in the middle of the circuit. In the diagram below, the additional switch is shown in one position in the upper box and in the other position below.

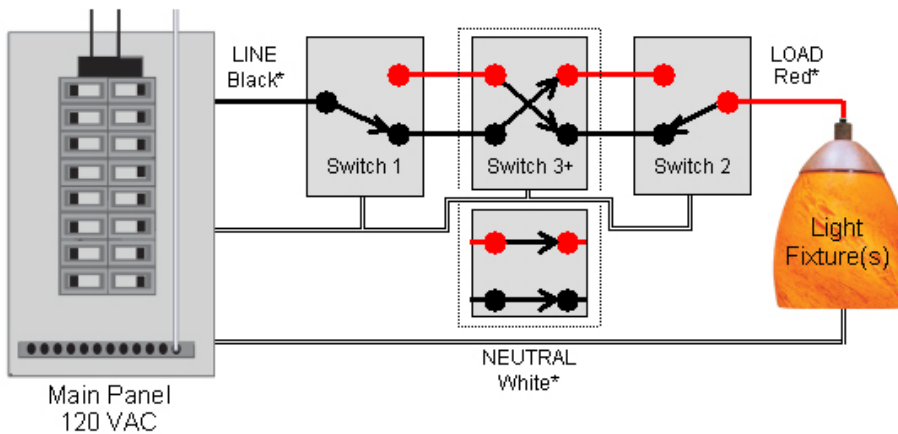

To learn more about multi-way circuits, go to Google.com or another search engine on the Internet and enter the search terms "three-way switch" or "four-way switch."

Using SwitchLinc Dimmers in Virtual Multi-Way Circuits

In a *virtual* multi-way circuit, only one SwitchLinc Dimmer, called the *SwitchLinc Primary*, actually controls the LOAD in the multi-way circuit. Any additional SwitchLinc Dimmers, called *SwitchLinc Secondaries*, are not connected to the LOAD, but only to the powerline (by being wired to the LINE and NEUTRAL). All of the SwitchLinc Dimmers can communicate with one another using INSTEON networking on the powerline. After wiring in the SwitchLinc Dimmers, you create the virtual multi-way circuit by setting up all of the SwitchLinc Dimmers to control each other (see *HOW TO SET UP SWITCHLINC DIMMER TO REMOTELY CONTROL AN INSTEON DEVICE*, below).

The diagram below shows how you convert a wired-in three-way circuit into a virtual three-way circuit using two SwitchLinc Dimmers. Step-by-step instructions for wiring in the SwitchLinc Dimmers are in the next section.

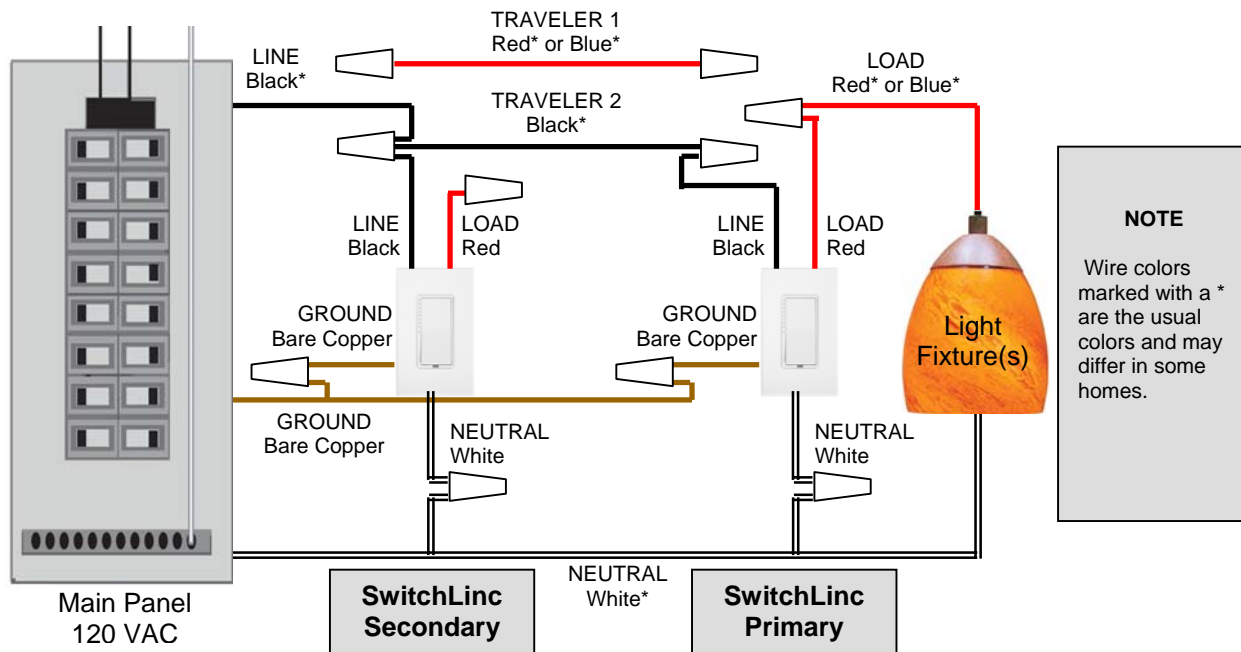

Notice that one of the TRAVELER wires (number 1, the red one) is not used, so you will cap it off at both ends with a wire nut.

The other TRAVELER (number 2, the black one) you will convert to a LINE wire. In the junction box where the SwitchLinc Secondary is, connect TRAVELER 2 to the existing LINE and also to the SwitchLinc Secondary's LINE wire. In the other junction box at the other end, you will connect TRAVELER 2 to the SwitchLinc Primary's LINE wire.

The SwitchLinc Primary's LOAD wire gets connected to the actual lights that are being controlled.

The LOAD wire for any SwitchLinc Secondaries that you will be installing will not be connected to anything, so cap those LOAD wires off with a wire nut.

All SwitchLinc Dimmers, whether they are Primaries or Secondaries, must be connected to NEUTRAL and to GROUND. Note that the switches you are replacing will not normally have a connection to NEUTRAL. If there is no NEUTRAL wire in the junction box (SwitchLinc Dimmer *will not function* without a neutral), please consult an electrician or call SmartLabs Tech Support, 866-243-8018.

Step-by-Step Instructions for Installing Multi-Way SwitchLinc Dimmers

When replacing a three-way mechanical switch, each switch will have three wires connected to it from the wall box. Four-way or greater circuits will have four wires connected to the switches in the center of the circuit. For this tutorial, we will follow the most commonly used wire colors for homes in North America.

1. **Find the LINE wire.** Your first task is to find out which switch junction box is the one where the electricity comes into the circuit. This box will contain the LINE wire (sometimes called HOT).

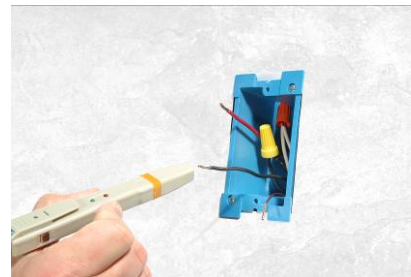

- a. Turn off the electricity at the circuit breaker panel.
- b. Pull all the switches in the multi-way circuit out of their junction boxes. Each switch should have three wires connected to it. If the circuit is a four-way or greater, some of the switches will have four wires.
- c. Disconnect the wires from the old switches. If the wires cannot be detached by unscrewing them, cut the wires where they enter the switch, then strip ½ inch of insulation off the ends.
- d. Making sure that none of the wires are touching anything and that no one is around the wall boxes, turn the electricity back on.
- e. Using a voltmeter or voltage sensor, individually test each wire for voltage. When you measure 120 Volts AC, that wire is the LINE wire. LINE wires are usually black.
- f. The other two wires, usually black and red, are the TRAVELERS and go to the next junction box. TRAVELER wires are usually in the same cable sheath.
- g. Turn off the electricity to resume installing the new SwitchLinc Dimmers.

2. **Connect the SwitchLinc Secondary's LINE Wire.** The SwitchLinc Dimmer that will be the Secondary goes in the junction box where you found the LINE wire. Connect the black LINE wire that you found, the black TRAVELER, and the Black LINE wire on SwitchLinc Dimmer all together with a single wire nut.



SwitchLinc V2 Dimmer 1000W User's Guide



3. **Cap the other TRAVELER wire.** The other TRAVELER wire, usually red, will not be used, so put a wire nut on the end of it.

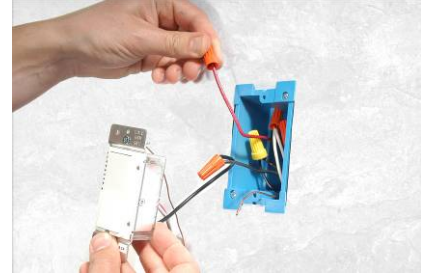

4. **Cap the red LOAD wire from the SwitchLinc Secondary.** Put a wire nut on the end of the SwitchLinc Secondary's LOAD wire to ensure that it won't connect to anything.

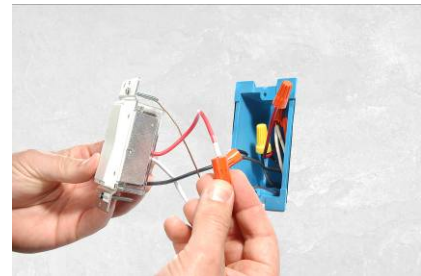

5. **Connect the SwitchLinc Secondary's NEUTRAL Wire.** Locate the group of NEUTRAL wires, usually white, in the rear of the box. The old switch should not have been connected to the NEUTRAL wires, but SwitchLinc Dimmer requires this connection in order to draw a small amount of power for itself (SwitchLinc Dimmer *will not function* without a neutral). Connect SwitchLinc Secondary's white NEUTRAL wire to the other NEUTRAL wires with a wire nut.

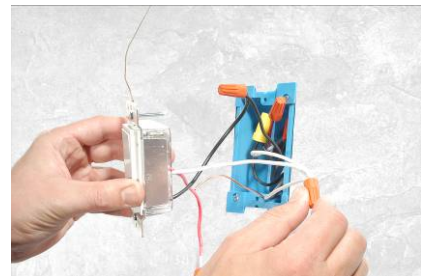

- 6. Connect the SwitchLinc Secondary's GROUND Wire.** Connect the bare copper GROUND wire to the other GROUND wires in the junction box.

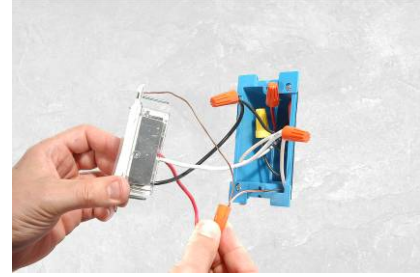

- 7. Install Additional SwitchLinc Secondaries.** If you have a four-way or greater switching circuit, see *Special Treatment for Four- or More-Way Circuits* at the end of this section.
- 8. Identify the Wires for the SwitchLinc Primary.** The SwitchLinc Primary is the SwitchLinc Dimmer that will actually control the LOAD. In the remaining junction box where you will install the SwitchLinc Primary, find the wire that carries power from the switch to the lights. This wire, called the LOAD wire, is commonly red.

In the same junction box, there will also be the two TRAVELER wires from the first box, often both in the same cable sheath. Identify the one TRAVELER wire (black) that you connected the LINE wire to in the first junction box.

If you're not sure which is the TRAVELER wire connected to the LINE wire, you can use the same method described earlier to find it. Turn on the power (taking the same precautions), and use a voltmeter to find the wire with 120 Volts AC on it. This wire is the TRAVELER wire that you connected to the LINE wire in the first junction box.

Make sure the power is turned off again before proceeding.

- 9. Connect the SwitchLinc Primary's LINE Wire.** Use a wire nut to connect the TRAVELER wire, usually black, that you identified as connected to the LINE wire to the SwitchLinc Primary's black LINE wire.

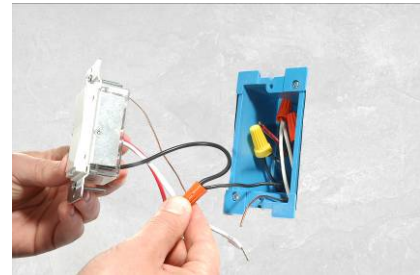

10. **Cap the other TRAVELER wire.** The other TRAVELER wire, usually red, will not be used, so put a wire nut on the end of it.

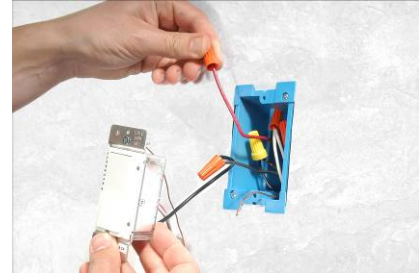

11. **Connect the SwitchLinc Primary's LOAD Wire.** Use a wire nut to connect the LOAD wire, usually red, to the SwitchLinc Primary's red LOAD wire.

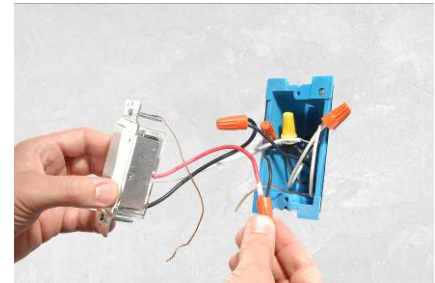

12. **Connect the SwitchLinc Primary's NEUTRAL and GROUND Wires.** Follow the same instructions as before in Steps 5 and 6 for the SwitchLinc Secondary.
13. **Return to the installation instructions on page 7 and continue on with step 7.**

Special Treatment for Four- or More-Way Circuits

If your lighting circuit includes more than two switches controlling a single set of lights, those extra switches will have four wires connected to them. Two of the wires are TRAVELERS from the preceding switch and the other two are TRAVELERS to the next switch in the chain. You will be converting the black TRAVELER wires to LINE wires and replacing the old four-wire switches with SwitchLinc Secondaries.

1. **Connect the SwitchLinc Secondary's LINE Wire.** Use a wire nut to connect both black TRAVELER wires to the SwitchLinc Primary's black LINE wire.
2. **Cap the Two Unused TRAVELERS.** The other two TRAVELER wires, usually red, will not be used, so put wire nuts on the ends of them.
3. **Cap the red LOAD wire from the SwitchLinc Secondary.** Put a wire nut on the end of the SwitchLinc Secondary's LOAD wire to ensure that it won't connect to anything.
4. **Connect the SwitchLinc Secondary's NEUTRAL and GROUND Wires.** Use the same instructions given previously in Steps 5 and 6.

HOW TO SET UP SWITCHLINC DIMMER TO REMOTELY CONTROL AN INSTEON DEVICE

Linking SwitchLinc Dimmer to a Controlled INSTEON Device

To use SwitchLinc Dimmer as an INSTEON Controller, follow these steps to link SwitchLinc Dimmer and a controlled INSTEON Device together. Refer to your INSTEON Device's User's Guide for detailed instructions on how to properly install it and link it to SwitchLinc Dimmer. The following will work for the most common INSTEON Devices.

1. Set SwitchLinc Dimmer to **Linking Mode** by pressing and holding the **Paddle Top** for 10 seconds until the top LED in the LED Bar begins blinking slowly and the controlled light flashes. Don't let up too soon – 10 seconds is a pretty long time!



BE CAREFUL
Any paddle press will exit Linking Mode early.

2. Select your INSTEON Device from the list below and follow the linking method for that Device. You have about 4 minutes to perform this step before SwitchLinc Dimmer's Linking Mode times out automatically.



- A. **A Second SwitchLinc Dimmer** – Press and hold the Second SwitchLinc Dimmer's **Paddle Top** for 10 seconds, then release. To confirm linking, the Second SwitchLinc Dimmer will blink the top LED in its LED Bar and flash the light that it is wired to.



- B. **LampLinc™ V2 Dimmer** – Press and hold the **SET Button** on the side of LampLinc V2 Dimmer for 3 seconds, then release. To confirm linking, LampLinc V2 Dimmer will blink its Status LED and flash the lamp that it is controlling.



- C. **ApplianceLinc™ V2** – Press and hold the **SET Button** on the side of ApplianceLinc V2 for 3 seconds, then release. To confirm linking, ApplianceLinc V2 will blink its Status LED.



- D. **KeypadLinc™ V2** – Press and hold the **ON Button** at the top of KeypadLinc V2 for 10 seconds, then release. To confirm linking, KeypadLinc V2 will blink the ON Button and flash the light that it is wired to.



- E. **Other INSTEON Devices** – See the INSTEON Device's User's Guide.

3. Go back to the SwitchLinc Dimmer that you placed in Linking Mode. If linking was successful, the top LED in its LED Bar will not be blinking but will remain steadily on.
4. Test that your INSTEON Device is working as expected by pressing the **Paddle Top** and **Paddle Bottom**.

Unlinking a Controlled INSTEON Device from SwitchLinc Dimmer

If you are no longer going to use an INSTEON Device that has previously been linked to SwitchLinc Dimmer, it is very important that you unlink it, because otherwise SwitchLinc Dimmer will retry any commands intended for the unused INSTEON Device, thus slowing down your system.

1. Set SwitchLinc Dimmer to **Linking Mode** by pressing and holding the **Paddle Top** for 10 seconds until the top LED in the LED Bar begins blinking slowly and the controlled light flashes.
2. Set SwitchLinc Dimmer to **Unlinking Mode** by pressing and holding the **Paddle Top again** for 10 seconds until the controlled light flashes again.
3. Follow the same method given above that you used to link your INSTEON Device to unlink it. On most INSTEON Devices, you just push an **ON Button** for 10 seconds or a **SET Button** for 3 seconds.
4. Go back to the SwitchLinc Dimmer that you placed in Unlinking Mode. If linking was successful, the top LED in its LED Bar will not be blinking but will remain steadily on.

Creating an INSTEON Scene

INSTEON Scenes let you activate dramatic lighting moods with the press of just one button. INSTEON Scenes are very easy to set up – just link more than one INSTEON Device to SwitchLinc Dimmer. Then, when you press either the Paddle Top or Paddle Bottom on SwitchLinc Dimmer, all of the INSTEON Devices linked in the scene will respond as a group. You can link multiple INSTEON Devices to multiple of INSTEON Controllers.

To add an additional INSTEON Device to a scene controlled by SwitchLinc Dimmer, simply follow the same procedure as above in *Linking SwitchLinc Dimmer to a Controlled INSTEON Device*. To remove an INSTEON Device from a scene, see *Unlinking a Controlled INSTEON Device from SwitchLinc Dimmer*.

TIP

You can avoid having to hold SwitchLinc Dimmer's Paddle Top down for 10 seconds for each INSTEON Device in a scene by placing SwitchLinc Dimmer in **Scene Setup Mode**, also called **Multilink Mode**.

1. Set SwitchLinc Dimmer to Scene Setup Mode by pressing and holding the **Paddle Top** for 10 seconds, then pressing the **SET Button** at the bottom of the paddle. SwitchLinc Dimmer's top LED in the LED Bar will blink slowly.



2. Follow the linking method given above for the INSTEON Device you want to include in the scene. On most INSTEON Devices, you just push an ON Button for 10 seconds or a SET Button for 3 seconds. SwitchLinc Dimmer will flash its controlled light to confirm linking, and the top LED in its LED Bar will continue to blink slowly.
3. On some INSTEON Devices, you may be able to set up additional features, such as On-Levels or Ramp Rates at this time.
4. Continue Steps 2 and 3 for any additional INSTEON Devices you want to link to the scene.
5. When you are finished linking INSTEON Devices to SwitchLinc Dimmer, complete Scene Setup by pressing the **Paddle Top** (actually, *any* button press will terminate Scene Setup). The top LED in SwitchLinc Dimmer's LED Bar will stop blinking and remain steadily on. You have about 4 minutes of inactivity before SwitchLinc Dimmer's Scene Setup Mode times out automatically.

HOW TO SET UP SWITCHLINC DIMMER TO BE REMOTELY CONTROLLED BY AN INSTEON CONTROLLER

Linking an INSTEON Controller to SwitchLinc Dimmer

To remotely control SwitchLinc Dimmer using another INSTEON Controller, follow these steps to link SwitchLinc Dimmer and the INSTEON Controller together. Refer to your INSTEON Controller's User's Guide for detailed instructions on how to properly install it and link it to SwitchLinc Dimmer. The following will work for the most common INSTEON Controllers.

1. Select your INSTEON Controller from the list below and follow the method shown to put it into **Linking Mode**.



- A. **A Second SwitchLinc V2 Dimmer** – Press and hold the Second SwitchLinc Dimmer's **Paddle Top** for 10 seconds, then release. To confirm that it is in Linking Mode, the Second SwitchLinc Dimmer will flash the light that it is wired to once and begin blinking the top LED in its LED Bar.



- B. **ControLinc™ V2 Tabletop Controller** – Choose the ON/OFF Button Pair you want to use for controlling SwitchLinc Dimmer. Press and hold the **ON Button** of the pair for 10 seconds. To confirm that it is in Linking Mode, ControLinc V2's Status LED will begin blinking.



- C. **KeypadLinc™ V2** – Choose the ON Button you want to use for controlling SwitchLinc Dimmer. Press and hold the **ON Button** for 10 seconds. To confirm that it is in Linking Mode, KeypadLinc V2 will flash the light that it is wired to once and begin blinking the ON Button that you pushed.



- D. **Other INSTEON Controllers** – See the INSTEON Controller's User's Guide.

2. Press and hold the **Paddle Top** for 10 seconds on the SwitchLinc Dimmer that is being controlled. To confirm linking, the SwitchLinc Dimmer will blink the top LED in its LED Bar and flash the light that it is wired to. Depending on the INSTEON Controller, you have about 4 minutes to perform this step before Linking Mode times out automatically.



Unlinking SwitchLinc Dimmer from an INSTEON Controller

If you are no longer going to control a SwitchLinc Dimmer with an INSTEON Controller, it is very important that you unlink it, because otherwise the controller will retry any commands intended for the unused SwitchLinc Dimmer, thus slowing down your system.

1. Select your INSTEON Controller from the list below and follow the method shown to put it into **Unlinking Mode**.



- A. **A Second SwitchLinc V2 Dimmer** – Follow the instructions in the section *Unlinking a Controlled INSTEON Device from SwitchLinc Dimmer*, above. (Briefly, press and hold the Second SwitchLinc Dimmer's **Paddle Top** for 10 seconds **twice**.)



- B. **ControlLinc™ V2 Tabletop Controller** – Press and hold the **OFF Button** of the ON/OFF Button Pair you used for controlling SwitchLinc Dimmer for 10 seconds. To confirm that it is in Unlinking Mode, ControlLinc V2's Status LED will begin blinking.



- C. **KeypadLinc™ V2** – Press and hold for 10 seconds the **ON Button** you used for controlling SwitchLinc Dimmer, then press and hold the same **ON Button** for 10 seconds **again**. To confirm that it is in Unlinking Mode, KeypadLinc V2 will flash the light that it is wired to once and begin blinking the ON Button that you pushed.



- D. **Other INSTEON Controllers** – See the INSTEON Controller's User's Guide.

2. Press and hold the **Paddle Top** for 10 seconds on the SwitchLinc Dimmer that is being controlled. To confirm unlinking, the SwitchLinc Dimmer will blink the top LED in its LED Bar and also the light that it is wired to. Depending on the INSTEON Controller, you have about 4 minutes to perform this step before Unlinking Mode times out automatically.





HOW TO SET UP ON-LEVELS AND RAMP RATES

Setting the On-Level and Ramp Rates (Optional)

The **On-Level** is the brightness that the light you are controlling will go to when you turn it on. The On-Level is adjustable from OFF to 100% brightness. The default is 100%.

The **Ramp Rate** sets the time it will take for the light you are controlling to go from OFF to the On-Level brightness, or from the On-Level brightness to OFF. This time is adjustable from 0.1 to 9 seconds to ramp between full-ON and full-OFF. The default is 0.1 second.

SwitchLinc Dimmer can store many On-Levels and Ramp Rates in its memory.

Local On-Level and Ramp Rate values apply when you tap the Paddle Top or Paddle Bottom on SwitchLinc Dimmer itself.

Remote-Controlled On-Level and Ramp Rate values apply when another INSTEON Controller tells SwitchLinc Dimmer to turn on or turn off. SwitchLinc Dimmer stores *separate* On-Levels and Ramp Rates for each button on each Controller that it is linked to. These On-Levels and Ramp Rates can all be the same, or they can be different.

You establish an On-Level and Ramp Rate by first setting them up and then locking them in. Setting an On-Level and setting a Ramp Rate are always done the same way, but locking them in is different, depending on what you want the On-Level and Ramp Rates to apply to.

You can set up an On-Level or Ramp Rate in any order. When you do the lock-in, the currently-set On-Level and Ramp Rate are locked in together.

Setting the On-Level

1. Hold down SwitchLinc Dimmer's Paddle Top or Paddle Bottom to **adjust the brightness** of the controlled light to the desired On-Level.
2. Press the **SET Button** at the bottom of the paddle.
3. SwitchLinc Dimmer will flash the controlled light once to confirm the On-Level setting.

BE CAREFUL

If SwitchLinc Dimmer is flashing an LED in its LED Bar, you held the SET Button down too long. Holding down the SET Button for 3 seconds is an alternate way to place SwitchLinc Dimmer into Linking Mode. To exit Linking Mode, tap the Paddle Top.



Setting the Ramp Rate

The Ramp Rate sets the time it will take for the light you are controlling to go from OFF to the On-Level brightness, or from the On-Level brightness to OFF. This time is adjustable from 0.1 to 9 seconds to ramp between full-ON and full-OFF. The default is 0.1 second.

1. Hold down SwitchLinc Dimmer's Paddle Top or Paddle Bottom to **adjust the Ramp Rate** of the controlled light. Adjust the Ramp Rate to be faster by brightening the light, or adjust it to be slower by dimming the light. The table below gives the approximate relationship between the brightness you set and the Ramp Rate you get.

Approximate Brightness Level	Ramp Rate in Seconds
90-100%	0.1
77-87%	0.2
65-74%	0.3
52-61%	0.5
39-48%	2.0
26-35%	4.5
13-23%	6.5
1-10%	8.5
1%	9.0

NOTE

If the light is ramping to less than full brightness, then the time it will take will be proportionately less. For instance, if the light is going to half brightness, the time it will take for a given Ramp Rate will be halved.

2. **Double-press** the **SET Button** at the bottom of the paddle.
3. SwitchLinc Dimmer will flash the controlled light once to confirm the Ramp Rate setting.

BE CAREFUL

If you got two flashes of the light, you didn't double-press the SET Button fast enough, and SwitchLinc Dimmer incorrectly thought you set up the On-Level twice. Re-set the correct On-Level and try the Ramp Rate setting again.

Locking In a Remote-Controlled On-Level and Ramp Rate

Whenever you link an INSTEON Controller to SwitchLinc Dimmer, the current On-Level and Ramp Rate values are stored in SwitchLinc Dimmer's memory. So, locking in a remote-controlled On-Level and Ramp Rate is really just the same as linking. Just follow the instructions in the section *Linking an INSTEON Controller to SwitchLinc Dimmer*, above.

Linking an INSTEON Controller to SwitchLinc Dimmer restores the previous values for the *Local* On-Level and Local Ramp Rate. So, linking does not affect the Local On-Level and Ramp Rate.

Locking In a Local On-Level and Ramp Rate

To lock in the current On-Level and Ramp Rate as the Local On-Level and Ramp Rate, all you have to do is **not link** SwitchLinc Dimmer to an INSTEON Controller for **four minutes**. After the four-minute timeout, the current On-Level and current Ramp Rate will be permanently locked in as the Local On-Level and Local Ramp Rate.



HOW TO CROSS-LINK MORE THAN ONE SWITCHLINC DIMMER

Cross-Linking in a 3-Way Circuit

The purpose of cross-linking switches allows you to track LED brightness levels as well as on/off levels on both the primary and secondary switches. For this example we will use a Primary switch controlling the load and one secondary switch in a virtual 3-way. They will be referred to as: Primary Switch (load controlling) and Secondary Switch.

Note: If you intend on setting a ramp rate or ON level; this should be done on each switch prior to cross-linking them. Please refer to the section above on How to set up SwitchLinc Dimmer to remotely control an INSTEON device for instructions on linking switches

1. Link Primary Switch to Secondary Switch.
2. Cross-link Secondary Switch to Primary Switch.

Upon successful completion, each switch in the above scenario will now track both ON/OFF status and brightness level on the LED bar of the other switches it has been cross-linked to.

Cross-Linking in a Multi-Way Circuit using Multi-Link Mode

For more than two switches, multi-link mode will allow you to save time. For this example we will use a Primary switch controlling the load and two secondary switches in a virtual 4-way. They will be referred to as: Primary Switch (load controlling), Secondary Switch 1, and Secondary Switch 2.

1. Primary Switch should be put into Multi-Link mode then link to Secondary Switch 1 and Secondary Switch 2. Tap the Primary Switch to go out of Multi-Link mode.
2. Secondary Switch 1 should be put into Multi-Link mode then link to Primary Switch and Secondary Switch 2. Tap the Secondary Switch 1 to go out of Multi-Link mode.
3. Secondary Switch 2 should be put into Multi-Link mode then link to Primary Switch and Secondary Switch 1. Tap the Secondary Switch 2 to go out of Multi-Link mode.

Upon successful completion, each switch in the above scenario will now track both ON/OFF status and brightness level on the LED bar of the other switches it has been cross-linked to.

ADVANCED FEATURES OF SWITCHLINC DIMMER

Restoring Power to SwitchLinc Dimmer

SwitchLinc Dimmer stores all of its settings in non-volatile memory, so they are not lost even when power is removed. In the event of a power loss, SwitchLinc Dimmer will automatically return the light being controlled to the brightness level it had before the power was interrupted.

Resetting SwitchLinc Dimmer to Its Factory Default Settings

The factory reset procedure can be used to clear SwitchLinc Dimmer's memory and restore its factory default settings. This procedure will clear the unit of all INSTEON Links, and any programmed On-Levels, Ramp Rates, X10 Primary Address, or X10 Scene Addresses.

3. Before resetting a SwitchLinc Dimmer that has been linked to an INSTEON Controller, be sure to unlink it from the Controller first. See *Unlinking SwitchLinc Dimmer from an INSTEON Controller*, above.
4. If you are using SwitchLinc Dimmer to control any INSTEON Devices other than the light it is wired to, unlink those Devices from SwitchLinc Dimmer. See *Unlinking a Controlled INSTEON Device from SwitchLinc Dimmer*, above.
5. Gently pull the SET Button at the bottom of the paddle out as far as it will go (about 1/8"). This "Air Gap" removes all power to SwitchLinc Dimmer.
6. After 10 seconds, push the **SET Button** all the way down and hold for 3 seconds, then let up.
7. A few seconds after you let up on the SET button, SwitchLinc Dimmer will turn the light it is wired to fully ON, indicating that the factory reset is complete. SwitchLinc Dimmer is now reset to all the default settings and ready for fresh programming and use.

NOTE

Note: Unless they have been unlinked, INSTEON Devices that have been previously linked to SwitchLinc Dimmer will still respond to paddle presses, even after a factory reset. The reason is that the INSTEON Devices themselves have not been unlinked from SwitchLinc Dimmer. Follow the procedure *Unlinking a Controlled INSTEON Device from SwitchLinc Dimmer*, above, to unlink individual INSTEON Devices.

X10 PROGRAMMING OPTIONS

SwitchLinc Dimmer is X10 ready, meaning that it can respond to X10 commands from an X10 Controller and it can send X10 commands to X10 devices. However, **to operate SwitchLinc Dimmer in X10 mode, you must first set up an X10 Primary Address.** As it ships from the factory, or after a factory reset procedure, SwitchLinc Dimmer will have no X10 Primary Address set up.

Setting the X10 Primary Address

You must do this before SwitchLinc Dimmer will respond to X10 commands. You can use any of the 256 possible X10 addresses for the X10 Primary Address.

1. Set SwitchLinc Dimmer to **Linking Mode** by pressing and holding the **Paddle Top** for 10 seconds until the top LED in the LED Bar begins blinking slowly and the controlled light flashes.
2. Using an X10 Controller, send the following sequence **three times in succession: X10 Primary Address** you want to assign followed by the **ON command**. For example, to assign the address A1, you would send "A1 ON A1 ON A1 ON". You have about 4 minutes to perform this step before SwitchLinc Dimmer's Linking Mode times out automatically.
3. Once SwitchLinc Dimmer has received the X10 Address three times, SwitchLinc Dimmer will confirm that it has set its Primary X10 Address by blinking the top LED in its LED Bar and flashing the light that it is wired to.

NOTE

An X10 Address consists of a House Code followed by a Unit Code. An X10 command, such as X10 ON or X10 OFF, may optionally follow the X10 Address.

Removing the X10 Primary Address

1. Set SwitchLinc Dimmer to **Linking Mode** by pressing and holding the **Paddle Top** for 10 seconds until the top LED in the LED Bar begins blinking slowly and the controlled light flashes.
2. Set SwitchLinc Dimmer to **Unlinking Mode** by pressing and holding the **Paddle Top again** for 10 seconds until the controlled light flashes again.
3. Using an X10 Controller, send the following sequence three times in succession: **assigned X10 Address** followed by the **OFF command**. You have about 4 minutes to perform this step before SwitchLinc Dimmer's Unlinking Mode times out automatically.
4. Once SwitchLinc Dimmer has received the X10 Address three times, SwitchLinc Dimmer will confirm that it has removed its Primary X10 Address by blinking the top LED in its LED Bar and flashing the light that it is wired to.



Setting the X10 On-Level and X10 Ramp Rate for the X10 Primary Address

When an X10 Controller sends an X10 ON or X10 OFF command to SwitchLinc Dimmer's Primary X10 Address, the Local On-Level and Local Ramp Rate apply. In other words, SwitchLinc Dimmer acts the same way as it would if you manually tapped its Paddle Top or Paddle Bottom.

See the section *HOW TO SET UP ON-LEVELS AND RAMP RATES*, above, for instructions on setting up the Local On-Level and Local Ramp Rate.

NOTE

If you want an X10 On-Level and Ramp Rate other than the Local values, you can set up one or more X10 Scene Addresses as described in the sections *Remotely Setting an X10 Scene Address and On-Level* and *Remotely Setting the Ramp Rate for an X10 Scene Address* below.

Enabling and Disabling X10 Resume Dim

If X10 Resume Dim is enabled, SwitchLinc Dimmer will remember the last brightness level to which it was set. Then, when an X10 ON command is received from an X10 Controller, the light will go to the remembered brightness, rather than to the X10 On-Level.

To enable X10 Resume Dim, set up a Local On-Level of OFF (or zero). To disable X10 Resume Dim, set up a Local On-Level of anything but OFF.

See the section *HOW TO SET UP ON-LEVELS AND RAMP RATES*, above, for instructions on setting up the Local On-Level.



ADVANCED X10 PROGRAMMING OPTIONS

You can remotely set up X10 Scene Addresses as well as On-Levels and Ramp Rates using an X10 Controller capable of sending an X10 address (house code and unit code) *without* sending X10 ON or OFF commands. The following procedures will not work with a transmitter that sends the X10 address and an X10 command together. X10 Controllers in which one button is pressed to turn an X10 device on or off WILL NOT WORK.

These procedures all begin by sending the same sequence of five X10 addresses, called the CLEAR Sequence. After you send the CLEAR Sequence, you have about 4 minutes to finish the procedure before automatic timeout.

Remotely Setting the On-Level for the X10 Primary Address

This method of setting the On-Level has exactly the same effect as manually setting the Local On-Level as explained in the section *HOW TO SET UP ON-LEVELS AND RAMP RATES*, above.

1. Using an X10 Controller, send the CLEAR Sequence:

O16	N16	M16	P16	M16
-----	-----	-----	-----	-----

2. Send the X10 Primary Address (house code and unit code).
3. Set the On-Level for the X10 Primary Address by adjusting SwitchLinc Dimmer's brightness using its paddle or any Controller. If you skip this step, the current On-Level will be used.
4. Send the following X10 Address sequence to lock in the new On-Level:

P16	N16	M16	O16	M16
-----	-----	-----	-----	-----

5. SwitchLinc Dimmer will flash the light it is wired to and blink an LED in its LED Bar, indicating that the On-Level has been set for the X10 Primary Address.

Remotely Setting the Ramp Rate for the X10 Primary Address

If you use this method for setting the Ramp Rate, you can achieve Ramp Rates ranging from 0.1 second to 9 *minutes*. If you use the manual method in the section *HOW TO SET UP ON-LEVELS AND RAMP RATES* above, you can only achieve Ramp Rates ranging from 0.1 second to 9 *seconds*.

This method of setting the Ramp Rate has exactly the same effect as manually setting the Local Ramp Rate as explained in the section *HOW TO SET UP ON-LEVELS AND RAMP RATES*, above.

1. Using an X10 Controller, send the CLEAR Sequence:

O16	N16	M16	P16	M16
-----	-----	-----	-----	-----

2. Send the X10 Primary Address (house code and unit code).
3. Use the paddle or any Controller to adjust SwitchLinc Dimmer's brightness so it corresponds to the Ramp Rate you want in the table below. If you use SwitchLinc Dimmer's paddle and you are careful, you can still set one of 32 brightnesses even though there are only 9 LED brightness indicators. Brighter is faster.



Bright-ness Level	Ramp Rate in Seconds	Bright-ness Level	Ramp Rate in Seconds	Bright-ness Level	Ramp Rate in Minutes
100%	0.1	65%	26	29%	2.5
97%	0.2	61%	28	26%	3.0
94%	0.3	58%	30	23%	3.5
90%	0.5	55%	32	19%	4.0
87%	2.0	52%	34	16%	4.5
84%	4.5	48%	38	13%	5
81%	6.5	45%	43	10%	6
77%	8.5	42%	47	6%	7
74%	19.0	39%	60	3%	8
71%	21.5	35%	90	0%	9
68%	23.5	32%	120		

- Send the following X10 Address sequence to lock in the new Ramp Rate:

O16 P16 N16 M16 O16

- SwitchLinc Dimmer will flash the light it is wired to and blink an LED in its LED Bar, indicating that the Ramp Rate has been set for the X10 Primary Address.

About X10 Scene Address Programming

SwitchLinc Dimmer can be a member of up to 255 X10 Scenes. An X10 Scene Address is just another X10 address like the X10 Primary Address. When an X10 ON command is sent to an X10 Scene Address, every X10 Scene-enabled module with that X10 Scene Address will turn on to its independent On-Level at its independent Ramp Rate. Sending an X10 OFF command to an X10 Scene Address will turn off all modules that are members of that X10 Scene, each at its independent Ramp Rate. X10 Scene-enabled modules will react to DIM and BRIGHT commands after the X10 Scene Address is sent. However, they will ignore ALL ON and ALL OFF commands for the X10 Scene Address.

Remotely Setting an X10 Scene Address and On-Level

- Using an X10 Controller, send the CLEAR Sequence:

O16 N16 M16 P16 M16

- Set the On-Level for the X10 Scene Address by adjusting SwitchLinc Dimmer's brightness using its paddle or any Controller. If you skip this step, the current On-Level will be used. A scene can trigger SwitchLinc Dimmer to go off by setting the On-Level to 0%.
- Send the following X10 Address sequence:

M16 N16 O16 P16

- Send the desired X10 Scene Address (house code and unit code) to lock in the new On-Level and X10 Scene Address.
- SwitchLinc Dimmer will flash the light it is wired to and blink an LED in its LED Bar, indicating that the X10 Scene Address and On-Level have been set up.

Remotely Removing an X10 Scene Address

- Using an X10 Controller, send the CLEAR Sequence:

O16 N16 M16 P16 M16

- Send SwitchLinc Dimmer's X10 Primary Address (house code and unit code).

SwitchLinc V2 Dimmer 1000W User's Guide



3. Send an X10 ON or OFF command.
4. Send the following X10 Address sequence:

O16	P16	M16	N16
------------	------------	------------	------------

5. Send the X10 Scene Address (house code and unit code) that is to be removed.
6. SwitchLinc Dimmer will flash the light it is wired to and blink an LED in its LED Bar, indicating that the X10 Scene Address has been removed.

Remotely Setting the Ramp Rate for an X10 Scene Address

The Ramp Rate of each module in each X10 Scene is adjustable. If this setting is not adjusted, SwitchLinc Dimmer will use the Ramp Rate for its X10 Primary Address.

1. Using an X10 Controller, send the CLEAR Sequence:

O16	N16	M16	P16	M16
------------	------------	------------	------------	------------

2. Send SwitchLinc Dimmer's X10 Primary Address (house code and unit code).
3. Use any controller to adjust SwitchLinc Dimmer's brightness so it corresponds to the Ramp Rate you want in the table below. If you use SwitchLinc Dimmer's paddle and you are careful, you can still set one of 32 brightnesses even though there are only 9 LED brightness indicators. Brighter is faster.

Bright-ness Level	Ramp Rate in Seconds	Bright-ness Level	Ramp Rate in Seconds	Bright-ness Level	Ramp Rate in Minutes
100%	0.1	65%	26	29%	2.5
97%	0.2	61%	28	26%	3.0
94%	0.3	58%	30	23%	3.5
90%	0.5	55%	32	19%	4.0
87%	2.0	52%	34	16%	4.5
84%	4.5	48%	38	13%	5
81%	6.5	45%	43	10%	6
77%	8.5	42%	47	6%	7
74%	19.0	39%	60	3%	8
71%	21.5	35%	90	0%	9
68%	23.5	32%	120		

4. Send the following X10 Address sequence:

N16	O16	P16	M16
------------	------------	------------	------------

5. Send the X10 Scene Address (house code and unit code).
6. SwitchLinc Dimmer will flash the light it is wired to and blink an LED in its LED Bar, indicating that the new Ramp Rate has been set for the X10 Scene Address.



HOW TO USE SWITCHLINC DIMMER

Using the Paddle

The Paddle Top makes your light go ON and the Paddle Bottom makes your light go OFF.

- **Tap** the Paddle Top to make your light go at the Local Ramp Rate from whatever brightness it currently has to the Local On-Level brightness.
- **Tap** the Paddle Bottom to make your light go at the Local Ramp Rate from whatever brightness it currently has to full-OFF.
- **Double-tap** the Paddle Top to make your light go full-ON quickly.
- **Double-tap** the Paddle Bottom to make your light go full-OFF quickly.
- **Press and hold** the Paddle Top to gradually brighten your light from whatever brightness it currently has to full-ON.
- **Press and hold** the Paddle Bottom to gradually dim your light from whatever brightness it currently has to full-OFF.

Paddle	Tap	Double Tap	Press and Hold
Top	Ramp to On-Level	Fast ON	Brighten
Bottom	Ramp to OFF	Fast OFF	Dim

Using the Air Gap

Pulling the SET Button at the bottom of the paddle out as far as it will go (about 1/8") opens mechanical contacts that remove all power from SwitchLinc Dimmer and the load that it controls. "Air gapping" can be useful for replacing bulbs or any other time you want the controlled circuit to be unpowered.

Because SwitchLinc Dimmer's settings are stored in non-volatile memory, setup information will not be lost when the unit unpowered.

BE CAREFUL

If you press the SET Button in too far when you undo the air gap, you might inadvertently reset SwitchLinc V2 Dimmer to its factory default settings. Just push the button in until its top is even with the Trim Frame.

COLOR OPTIONS FOR SWITCHLINC DIMMER

Paddle and LED Colors are Changeable

You can change the color of SwitchLinc Dimmer's LEDs and also its paddle and trim frame to match the décor of any room.

SwitchLinc Dimmer comes standard with a white paddle assembly. You can optionally purchase ivory (#2400I), almond (#2400AL), black (#2400BK), brown (#2400BR), or gray (#2400GY) SwitchLinc Color Change Kits from www.smarthome.com.

Light-pipe color change kits for the LEDs are also available from www.smarthome.com. Each SwitchLinc Indicator Color Change Kit (#2400L) contains five each of blue, red, green, amber, and clear light-pipes.

How to Change Paddle and LED Colors

You can remove the front paddle and trim frame assembly before or after SwitchLinc Dimmer is installed. During the changeover process, the power and the load may remain on and operating. There are no dangerous voltages or unsafe areas under the paddle.

1. If SwitchLinc Dimmer is already installed in the wall, remove the faceplate from the switch junction box.
2. Remove the four Phillips screws that hold the paddle assembly to the metal frame.
3. Pull the entire paddle frame straight away from the switch. You may have to wiggle the bottom of the frame to get it free of the bottom SET Button.

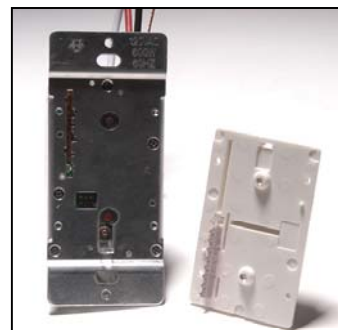

Paddle Assembly and
SwitchLinc body separated

4. Using a flat blade, remove the large light pipe as shown. The light pipe will snap out of the frame. Do the same for the small light pipe.



Snap out the light pipes with a
flat tool

SwitchLinc V2 Dimmer 1000W User's Guide



5. Orient the new small light pipe with its protrusion facing toward the center of the frame and snap it into place. If placed in backwards or reversed, it will not click into place. Refer to the diagram.
6. Orient the new large light pipe with the side that has the most protrusions facing toward the center of the frame. Using only finger pressure, snap the light pipe into the frame.

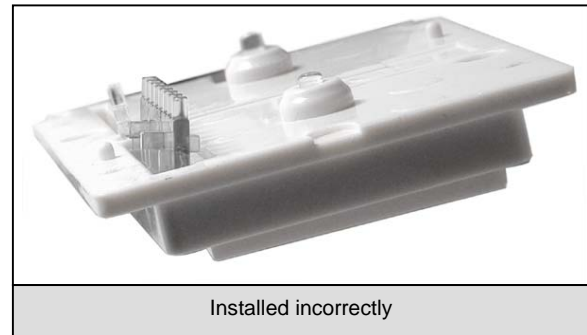
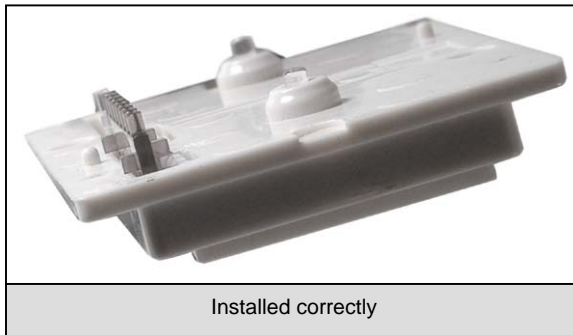
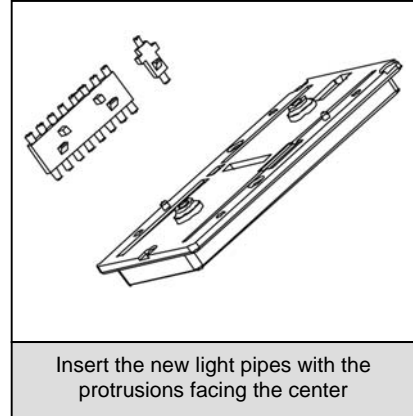

7. If both light pipes are installed correctly, they will stick straight out from the back of the frame. If installed incorrectly, they will appear to be tilted as shown in the photos.
8. Gently place the paddle assembly back onto the front of SwitchLinc Dimmer. A little force may be necessary to snap the assembly over the SET Button. Reinstall the four screws that you removed in Step 2.

ABOUT INSTEON

Understanding Why an INSTEON Network Is Reliable

INSTEON messages travel throughout the home via Powerline Carrier (PLC) signals on the existing house wiring, and also via wireless Radio Frequency (RF). As the messages make their way to INSTEON devices being controlled, they are picked up and retransmitted by all other INSTEON devices along the way. This method of communicating, called a *mesh network*, is very reliable because each additional INSTEON device helps to support the overall network.

To further ensure reliability, every INSTEON device confirms that it has received a command. If an INSTEON Controller does not receive this confirmation, it will automatically retransmit the command up to five times.

Further Enhancing Reliability

As signals travel via the powerline or RF throughout the home, they naturally become weaker the farther they travel. The best way to overcome signals getting weaker is to increase the coverage of the mesh network by introducing more INSTEON devices.

It is possible that some audio-video products, computers, power strips or other electrical equipment may attenuate INSTEON signals on the powerline. You can temporarily unplug suspected devices to test whether the INSTEON signal improves. If it does, then you can plug in filters available from Smarthome that will permanently fix the problem.



Using Smarthome's SignalLinc RF to Upgrade Your INSTEON Network

SignalLinc™ RF Signal Enhancers are ideal for improving signal strength and network coverage throughout your home. In addition, two SignalLinc RFs provide a wireless path for INSTEON signals to travel between the two separate electrical circuits, called *powerline phases*, found in most homes. Without a reliable method for coupling opposite powerline phases, some parts of your home may receive INSTEON signals intermittently. With at least one SignalLinc RF plugged into one of the powerline phases, and at least one more plugged into the opposite powerline phase, INSTEON powerline signals will be strong everywhere in your home.





About INSTEON and X10

Possible BoosterLinc Interference with INSTEON

If you have installed older SmartLabs Plug-In BoosterLinc™ X10 Signal Boosters or certain other BoosterLinc-enabled products, the older BoosterLinc technology may interfere with INSTEON communications.

Plug-In BoosterLinc X10 Signal Boosters, SmartLabs #4827, shipped after February 1, 2005, with V3.0 or later firmware, are fully compatible with INSTEON.

The following Plug-In BoosterLinc X10 Signal Boosters use older firmware that may cause interference with INSTEON:

- White BoosterLinc X10 Signal Boosters, #4827, shipped before February 1, 2005, with V2.5 or earlier firmware
- All Gray BoosterLinc X10 Signal Boosters, #4827

Try unplugging the older BoosterLinc X10 Signal Boosters to see if this helps with INSTEON interference. If it does, please call 866-243-8018 for help with replacing your older BoosterLinc X10 Signal Boosters with newer INSTEON-compatible ones.

The following pre-INSTEON SmartLabs products have BoosterLinc technology that you can turn on or turn off when you set the X10 Address for the product. If turned on, the BoosterLinc technology may interfere with INSTEON.



- KeypadLinc™ 6 with Integrated Dimmer, #12073W, #12073WB and #12073WW



- SwitchLinc™ Relay 2-Way, #23883 and #23883T



- ToggleLinc™ 2-Way Dimmer, #23890, and Switch, #23893

NOTE

To disable BoosterLinc X10 Signal Amplification on these products:

1. Press and hold the SET Button.
2. Send the X10 Primary Address.
3. Send an X10 OFF command.

You can send an X10 ON command in Step 3 to re-enable the BoosterLinc feature.

If you have any of these products and the BoosterLinc feature is turned on, please consult your User's Guide or call 866-243-8018 for help with turning it off. You may then wish to install newer INSTEON BoosterLinc X10 Signal Boosters, which SmartLabs can help you with.

INSTEON's Effect on X10

If your existing X10 devices seem to be working less reliably after installing INSTEON devices, remember that INSTEON devices can absorb X10 signals just as X10 devices do, and that INSTEON devices do not repeat X10 signals. Installing INSTEON-compatible BoosterLinc X10 Signal Boosters, SmartLabs #4827, or a SignalLinc Plug-In Coupler-Repeater, #4826, can increase X10 signal levels.

Please call 866-243-8018 if you have any questions or would like more help.



TROUBLESHOOTING

Problem	Possible Cause	Solution
The LED Bar on my SwitchLinc Dimmer is not turning on at all and it won't control my light.	SwitchLinc Dimmer is not getting power.	Make sure the circuit breaker is turned on.
		Make sure the air gap (SET Button) is not pulled out.
		Check junction box wires to ensure all connections are tight and no bare wires are exposed.
		Check the light fixture to ensure all connections are tight and no bare wires are exposed.
The switch I'm replacing only has two wires.	SwitchLinc Dimmer needs a NEUTRAL wire in order to operate.	Look in the rear of the junction box for a group of white wires all tied together with a wire nut. Those are the NEUTRAL wires. Connect SwitchLinc Dimmer's white wire there.
My SwitchLinc Dimmer is not receiving signals from INSTEON or X10 Controllers.	The SwitchLinc Dimmer and the Controller are on opposite powerline phases.	Make sure two SignalLinc RF Signal Enhancers are properly installed to bridge the two powerline phases.
	The Controller is plugged into a power strip.	Powerline signals can't travel through power filters. Plugging the Controller directly into a wall outlet works best.
	Other modules are loading down the signal.	Move the other modules or the Controller to another outlet.
My SwitchLinc Dimmer is not linking to or working with an INSTEON Controller or Device.	The INSTEON signal may be too weak.	Add new INSTEON devices or move around existing INSTEON devices. All INSTEON devices act as INSTEON Network repeaters.
		Make sure you are not experiencing interference with older X10 BoosterLinc technology. Upgrade to INSTEON BoosterLincs.
My SwitchLinc Dimmer doesn't always respond to an INSTEON Controller.	The INSTEON Controller may have been reset without first unlinking SwitchLinc Dimmer from it.	Re-link SwitchLinc Dimmer to the INSTEON Controller.
The light turned on by itself.	Another Controller, a timer, or stray X10 signals triggered SwitchLinc Dimmer.	Check scene membership and remove any unwanted links from SwitchLinc Dimmer, or perform a Factory Reset to clear it.
		Install a powerline signal blocker in your home to keep X10 signals from neighboring homes from interfering. Consider not using SwitchLinc Dimmer in X10 mode.
		If the above doesn't work, perform a Factory Reset.
The controlled light does not appear to turn on or off right away.	The Ramp Rate may be set too slow.	Set a shorter Ramp Rate.
SwitchLinc Dimmer turns on, but not off, using another Controller.	The load is producing electrical noise that is interfering with SwitchLinc Dimmer's reception of powerline signal.	Install a powerline noise filter like SmartLabs' #4835 between the load and SwitchLinc Dimmer.
		Install additional INSTEON Devices to boost the INSTEON signal.
		Increase the X10 signal strength with an INSTEON-compatible X10 booster to overcome the powerline noise.
My light only turns off when I tap the Paddle Top on my SwitchLinc Dimmer, but I can brighten and dim it.	The On-Level may be set to fully-off or very dim.	Set a brighter On-Level. See <i>HOW TO SET UP ON-LEVELS AND RAMP RATES</i> , above

SwitchLinc V2 Dimmer 1000W User's Guide



Problem	Possible Cause	Solution
When I try to turn on my light with another Controller, the light turns on, then back off.	SwitchLinc Dimmer may be set up with an INSTEON On-Level at a high brightness and an X10 Primary or Scene Address On-Level at a low brightness.	Remove the X10 Primary Address or X10 Scene Address from SwitchLinc Dimmer.
		Remove the X10 Address from the button on your INSTEON Controller so it doesn't send both INSTEON and X10 commands.
When I press a button on my SwitchLinc Dimmer, it takes a long time for other INSTEON Devices it is controlling to respond.	You may have removed an INSTEON Device that your SwitchLinc Dimmer is trying to operate. SwitchLinc Dimmer is re-trying the missing INSTEON Device.	If the INSTEON Device is still available, unlink it from SwitchLinc Dimmer by following the directions in the section <i>Unlinking a Controlled INSTEON Device from SwitchLinc Dimmer</i> , above.
		Reset SwitchLinc Dimmer by following the directions in the section <i>Resetting SwitchLinc Dimmer to Its Factory Default Settings</i> , above.
My SwitchLinc Dimmer doesn't respond to X10 address A1 when I first set it up.	Unlike previous X10-only products, SwitchLinc Dimmer does not have an X10 Primary Address set up at the factory.	Set up an X10 Primary Address by following the instructions in the section <i>Setting the X10 Primary Address</i> .
I'm having difficulty performing advanced X10 programming	The X10 "MNOP" house and unit codes were sent in the wrong order.	Don't hold down the buttons on your X10 controller too long, to avoid duplicate codes being sent.
The load is buzzing when on or dim.	The dimming component inside SwitchLinc Dimmer "chops" the powerline sine wave to reduce the power.	The bulb filaments are vibrating. Use rough-service, 130-volt, or appliance grade bulbs to reduce the noise.
		Run SwitchLinc dimmer in the "full-on" mode or switch to a non-dimming SwitchLinc V2 Relay.
SwitchLinc Dimmer is locked up.	A surge or excessive noise on the powerline may have glitched it.	Pull the SET Button on SwitchLinc Dimmer all the way out for 10 seconds to air-gap it, then push it back in without pushing it all the way down.
		If the above doesn't work, see <i>Resetting SwitchLinc Dimmer to Its Factory Default Settings</i> , above.
SwitchLinc Dimmer is getting warm to the touch.	It is normal for wall dimmers to get warm (but not hot).	SwitchLinc Dimmer will dissipate about 1 Watt per 100 Watts controlled. Using metal junction boxes, removing insulation around the outside of the box, or controlling a smaller load can help lessen the heat.

If you have tried these solutions, reviewed this User's Guide, and still cannot resolve an issue you're having with SwitchLinc Dimmer, please:

- Search our online knowledge base at <http://smarthome.custhelp.com>.
- Call our Support Department at 866-243-8018.
- Email us at tech@smarthome.com.



SPECIFICATIONS

SwitchLinc Dimmer Specifications

General	
Smarthome Product Number	2476DH, INSTEON SwitchLinc V2 Dimmer 1000W Switch
Warranty	2 years
Operation	
On-Levels	32
Ramp Rates (full-ON to full-OFF)	0.125 to 9 seconds if programmed locally, 0.125 seconds to 9 minutes if programmed remotely
LED Bar Brightness Indicator	9 White LEDs, Optional Green, Blue, Amber, or Red with #2401 kit
Manual Operation Modes	INSTEON only, X10 only, INSTEON and X10 Combo Mode
Combo Mode Message Order	INSTEON, X10, INSTEON cleanup
Multi-Way Circuit Support	One SwitchLinc Dimmer controls load, Cross-Link any number of SwitchLinc Dimmers or other INSTEON Controllers
Setup Memory	Non-volatile EEPROM
INSTEON Features	
INSTEON Addresses	1 hard-coded out of 16,777,216 possible
INSTEON Links	417 out of 16,777,216 possible
INSTEON Powerline Frequency	131.65 KHz
INSTEON Minimum Transmit Level	3.2 V _{pp} into 5 Ohms
INSTEON Minimum Receive Level	1 mV _{pp} nominal
INSTEON Messages Repeated	Yes
X10 Features	
X10 Primary Address	1 optional (comes unassigned)
X10 Scene Addresses	255 possible
X10 Status Response	Supported
X10 Resume Dim	Supported (by setting Local On-Level to zero)
X10 Powerline Frequency	120 KHz
X10 Minimum Transmit Level	3.2 V _{pp} into 5 Ohms
X10 Minimum Receive Level	10 mV _{pp} nominal
X10 Messages Repeated	No

SwitchLinc V2 Dimmer 1000W User's Guide



Mechanical	
Paddle Type	True rocker action
Paddle and Trim Frame Color	White installed Optional Ivory, Almond, Black, Brown, or Gray with #2400xx kits
Wire Nuts	4 included
Mounting	Mounts in single or multiple-ganged junction box. Controls 200 watts less load for each immediately adjacent electronic dimmer installed. For example, 1000 watt load capacity becomes 800 watt with another electronic dimmer installed to the immediate right or left. Use a triple-gang box with a mechanical switch (or a non-dimming electronic switch like SwitchLinc Relay) in the center, to avoid de-rating.
Heat Dissipation	Four heat dissipation fins integrated into SwitchLinc Dimmer body. Individual fins can be permanently detached from switch if fins interfere with installation. Removal of each individual fin will reduce rated switch capacity by 100W.
Operating Conditions	Indoors, 40 to 104°F, up to 85% relative humidity
Dimensions	4.1" H x 1.8" W x 1.2" D
Weight	3.6 oz
Electrical	
Supply Voltage	120 Volts AC +/- 10%, 60 Hertz, single phase
Surge Protection	MOV rated for 150 Volts
Power Wire Leads	6", 16 AWG, stranded, 600V, 105°C insulation, ends stripped and tinned, LINE (black), LOAD (red), NEUTRAL (white)
Ground Lead	6", 18 AWG, stranded, bare copper
Load Types	Wired-in incandescent lighting devices
Maximum Load	1000 Watts (uses 12-Amp triac dimmer)
Minimum Load	No minimum load required
Certification	Safety tested for use in USA and Canada (ETL #3017581)



Certification

SwitchLinc V2 Dimmer has been thoroughly tested by ITS ETL SEMKO, a nationally recognized independent third-party testing laboratory. The North American ETL Listed mark signifies that the product has been tested to and has met the requirements of a widely recognized consensus of U.S and Canadian product safety standards, that the manufacturing site has been audited, and that the manufacturer has agreed to a program of quarterly factory follow-up inspections to verify continued conformance.



Limited Warranty

Seller warrants to the original consumer purchaser of this product that, for a period of two years from the date of purchase, this product will be free from defects in material and workmanship and will perform in substantial conformity to the description of the product in this User's Guide. This warranty shall not apply to defects or errors caused by misuse or neglect. If the product is found to be defective in material or workmanship, or if the product does not perform as warranted above during the warranty period, Seller will either repair it, replace it or refund the purchase price, at its option, upon receipt of the product at the address below, postage prepaid, with proof of the date of purchase and an explanation of the defect or error. The repair, replacement, or refund that is provided for above shall be the full extent of Seller's liability with respect to this product. For repair or replacement during the warranty period, call SmartLabs customer service to receive an RA# (return authorization number), properly package the product (with the RA# clearly printed on the outside of the package) and send the product, along with all other required materials, to:

SmartLabs, Inc.
ATTN: Receiving Dept.
16542 Millikan Ave.
Irvine, CA 92606-5027

smartlabs

Limitations

The above warranty is in lieu of and seller disclaims all other warranties, whether oral or written, express or implied, including and warranty or merchantability or fitness for a particular purpose. Any implied warranty, including any warranty of merchantability or fitness for a particular purpose, which may not be disclaimed or supplanted as provided above shall be limited to the one-year period of the express warranty above. No other representation or claim of any nature by any person shall be binding upon seller or modify the terms of the above warranty and disclaimer. In no event shall seller be liable for special, incidental, consequential, or other damages resulting from the possession or use of this product, including without limitation damage to property and, to the extent permitted by law, personal injury, even if seller knew or should have known of the possibility of such damages. Some states do not allow limitations on how long an implied warranty lasts and/or the exclusion or limitation of damages, in which case the above limitations and/or exclusions may not apply to you. You may also have other legal rights that may vary from state to state.

INSTEON, Plug-n-Tap, ControlLinc, TesterLinc, SignalLinc, LampLinc, ToggleLinc, BoosterLinc, ApplianceLinc, KeypadLinc, FilterLinc, ProbeLinc, SwitchLinc, TempLinc, IR Linc and SmarthomeLive are trademarks of SmartLabs, Inc. INSTEON networking technology is covered by pending U.S. and foreign patents.

© Copyright 2006 SmartLabs, Inc., 16542 Millikan Ave., Irvine, CA 92606-5027,
866-243-8018, 949-221-9200, www.smarthome.com