



VIB100 Instruction Manual

Piezo Electric Vibration Detector



The VIB100 is a fence mounted Piezo Electric Vibration Detector. It contains a custom integrated circuit with a Microchip RISC Processor. Both hardware and software have been designed to analyze the piezo electric signal filtering out common noises and responding to any assault on the fence, climbing or cutting.

GENERAL: The VIB100 consists of a circuit board potted inside of a NEMA 4X polycarbonate enclosure with two liquid tight wire cord grips at the bottom. There are three LEDs for identifying the response of the sensor to an attack upon the fence. There are three sets of jumpers – J1 and J2 for selecting the sensitivity of the sensor and J3 for turning on the LEDs. There is a programming connector and a power / output connector. The VIB100 has two outputs – alarm and power failure. The VIB100 may be used with any alarm control that accepts and open collector input.

SPECIFICATIONS:

Operating Voltage: 10-15VDC (regulated and filtered)

Power Consumption: 1mA (normal); 2mA (alarm)

Range: Up to 50 linear feet of fence, 25 ft on either side maximum

Alarm Output: 1 Open Collector – 15VDC 50mA Maximum, not to exceed supply voltage.

Power Failure Alarm Output: 1 Open Collector, Normally Closed when powered – 15VDC 50mA Maximum, not to exceed supply voltage.

Alarm Output Activation Time: 5 seconds

Alarm LEDs: 3 internal for testing purposes, may be disabled for power conservation

Installation: Hardwire – Four conductor, #22 AWG, twisted, shielded with drain (drain connected to ground) recommended

Operating Temperature: -20 deg to 120 deg F (-20 deg to 50 deg C)

Size: 4.70" high x 2.55" wide x 2.40" deep

Weight: 10 ounces

Color: Gray

MOUNTING:

Verify that the fence is in good physical condition with no loose or rattling parts. Tight fabric and rigid fence posts transmit vibrations best. The VIB100 has a greater range on a good quality fence. Consider testing a single unit, with a 9 volt battery, at various locations on the fence to verify the detection range possible on your particular fence.

Mount the VIB100 directly to the fabric of the chain link or wire mesh, on the interior side of the protected area as shown in the illustrated examples, at a height of 4-5 feet and 1 foot from a post.



The mounting hardware consists of an aluminum plate with two screws, used to clamp the sensor enclosure to the fence fabric.

Loosely secure the mounting bracket to the VIB100, with one screw only in the upper corner of the VIB100



Feed the bracket thru the fence fabric diagonally, down and to the right, capturing 2-3 wires, depending on link size.



Secure the other corner of the VIB100 to the bracket using the remaining screw, centering the VIB100 in the links and tighten so that the VIB100 makes good contact with the chain links. **DO NOT OVER TIGHTEN.**



There is no need to tighten so much that the bracket is pulled fully to the case and bent or that the case of the VIB100 case begins to twist and deform. This will prevent a water tight seal with the lid.

KEY COMPONENTS:

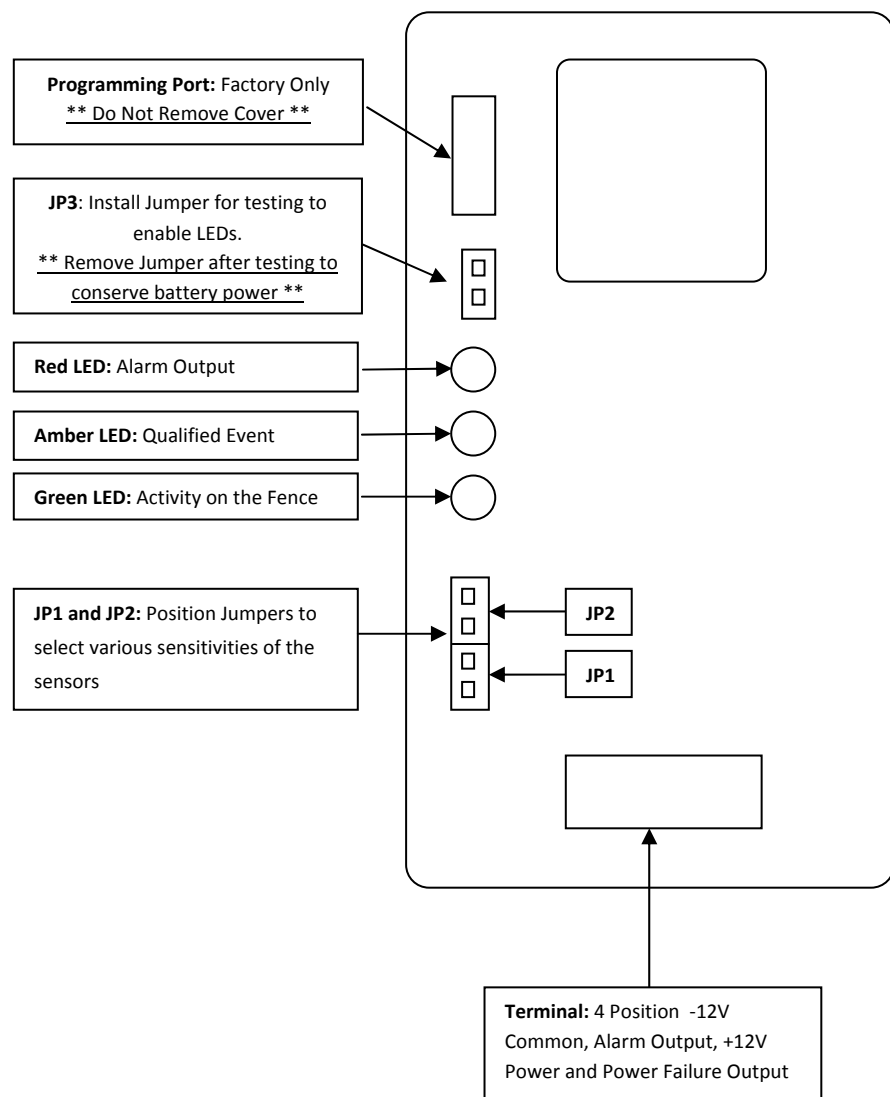

LEDs:

Each VIB100 has three LEDs – Green, Amber and Red. These LEDs indicate the response of the sensor to impacts or cuts to the fence.

Green LED - The Green LED will indicate that the VIB100 has received a signal from the impact and will process that signal to qualify it as a valid event. If the Green LED does not flash during a valid attack upon the fence, the sensitivity of the VIB100 must be increased, or the distance between the sensors reduced.

Yellow LED – The Yellow LED will indicate that the VIB100 has qualified a signal as a valid event. If the Green LED flashes, but the Yellow does not flash during a valid attack upon the fence, the sensitivity of the VIB100 must be increased, or the distance between the sensors reduced.

Red LED – The Red LED will indicate that the VIB100 has counted enough events to qualify as an alarm and produced an alarm output.

SELECTING THE SENSOR SENSITIVITY FOR YOUR FENCE:

The VIB100 Sensor has a built in microprocessor that counts and times the pulses generated by an impact to the fence. The different sensitivities allow you to select an alarm output specific to your fence that matches up with the quantity of pulses and duration of pulses of a valid attack.

In order to select the desired sensitivity required in your application, there are two removable jumpers – J1 and J2. The jumpers allow you to select from 4 pre-programmed alarm sensitivities – Low Sensitivity, Moderate Sensitivity, High Sensitivity and Highest Sensitivity.

J1 On, J2 Off = Low Sensitivity Profile

J1 Off J2 Off = Moderate Sensitivity Profile

Note: This is the default sensitivity

J1 Off, J2 On = High Sensitivity Profile

J1 On, J2 On = Highest Sensitivity Profile

Remove power to the VIB100 Sensor prior to changing jumpers. This can be done by removing the terminal block from the circuit board. Once Jumpers are put back in the desired position reconnect power by inserting terminal block back on circuit board. Make sure terminals are up and wires are in correct position. The Green LED will light momentarily indicating that the new sensitivity setting has been loaded.

Choosing the sensor sensitivity depends upon the quality of the fence (loose or tight, heavy or light link gauge, old or new), the height of the fence (short 5 ft. to regular 6-8 ft. to tall >8 ft.) and the surrounding environment (remote or public). Selecting the sensitivity is a balance between generating an alarm output upon a valid attack to the fence and filtering out nuisance events. On a new tight fence of regular height, the sensor will work well with a low to moderate sensitivity setting. On a loose or older fence, the VIB100 will work best with a high to highest sensitivity setting. High sensitivity settings can be selected for remote areas with no public access but low sensitivity settings are better for fences adjacent to public areas.

TESTING:

With the VIB100 mounted to the fence and the cover removed, select the sensitivity with Jumpers 1 and 2 per the guidelines above. Hook up a 9V battery to the sensor. Test the ability of the sensor to detect impacts and climbs at the desired range (30 to 50 feet). Move the sensor to various parts of the fence and test. The LEDs will alert you to the response of the sensor. One of the unique aspects of the Flair VIB100 is that each individual sensor can be tuned to a particular fence section. Often the quality of the fence can vary from one section to the next.

Decrease or increase the sensitivity of the sensor by changing Jumpers 1 and 2 to generate an alarm upon the degree of impact / attack to the fence you want to identify. A good rule of thumb is to select a sensitivity that generates an alarm at the 3rd or 4th step in a climb. At this sensitivity the sensor should not generate an alarm at a single impact to the fence.

When testing with a battery, you must disconnect the battery from the sensor after each test in order for the sensor counter and timer to reset. The counters will also reset once the sensor produces an alarm output and the RED LED flashes. Don't forget to disconnect the battery when changing the sensitivity setting also.

Once you have selected an appropriate sensitivity and sensor spacing, mount all of the sensors to the fence and wire to power and alarm control. At any time, the sensitivity of one or more of the VIB100 sensors may be changed to tune them to a particular section of fence or desired response.

WIRING:

The Alarm is an open collector output - normally open. The Power Trouble is an open collector output – normally closed. The Alarm Output will provide an electrical short to ground when activated. The Power Trouble Output will open when activated. **Refer to your Alarm Control Panel's Instruction Manual for instructions on how to wire open collector outputs to the zone inputs of the panel.**

Diagram 1: Output Electrical Configuration

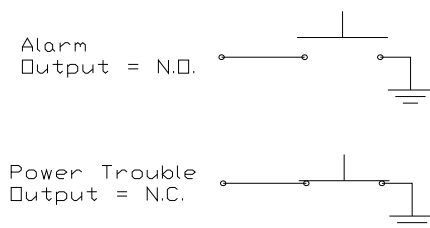

Position blue four pin wire connector so that terminals are at top.

Jumpers 1 and 2 are pressed on one pin only which is Off / Off = Default Sensitivity Moderate

Keep white five pin cover on serial port to protect pins.

WIRING (Continued):

The VIB100 may be wired with one loop for alarm and one loop for power trouble to be monitored by two zones on control panel or the alarm and power trouble may be combined on one loop.

Always connect the End-of-Line Resistors in the last VIB100 along the zone run.

Diagram 2: Wiring Diagram for separate alarm and power trouble loop

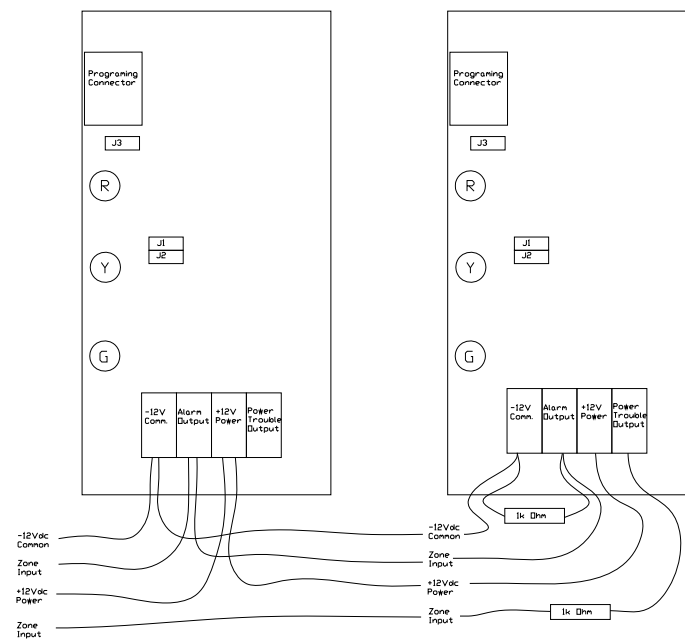
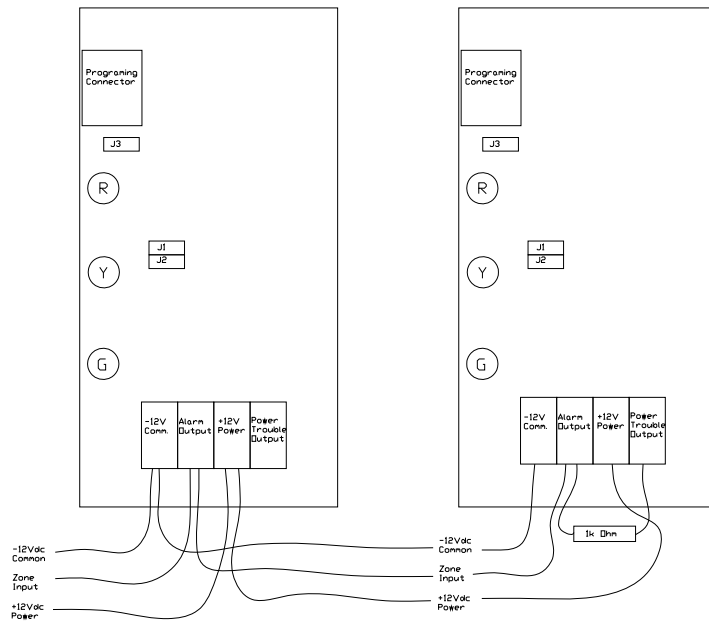

Diagram 3: Wiring Diagram for combined alarm and power trouble loop



For any single zone on your alarm panel, you can wire a single VIB100 or several together, in parallel, to increase the zone size.

Loosen the Liquid Tight Cordgrip and feed 8" of wire thru the bottom, into the box. Tighten the Liquid Tight cord grip.

Make connections as shown in previous wiring diagrams.



If you are connecting several VIB100 units together on a zone, first mount all units. Run all wires into the enclosures and secure the wire to the fence with wire ties before terminating wire at the connectors. Plug any unused Liquid Tight Cordgrip with the enclosed stainless steel plug.

Call Flair at any time to request help with installation – **800-532-3492**.

Limited Warranty:

Flair Electronics warrants the original purchaser that for a period of twelve months from the date of purchase, the product shall be free of defects in materials and workmanship under normal use. During the warranty period, Flair Electronics shall, at its option, repair or replace any defective product upon return of the product to its factory, at no charge for labor and materials. Any replacement and/or repaired parts are warranted for the remainder of the original warranty or ninety (90) days, whichever is longer. The original purchaser must promptly notify Flair Electronics in writing that there is a defect in materials or workmanship, such written notice to be received in all events prior to expiration of the warranty period. There is absolutely no warranty on software and all software products are sold as a user license under the terms of the software license agreement included with the product. The Customer assumes all responsibility for the proper selection, installation, operation and maintenance of any product purchased from Flair Electronics.

Warranty Procedure

To obtain service under this warranty, please return the item(s) in question to the point of purchase. All authorized distributors and dealers have a warranty program. Anyone returning goods to Flair Electronics must first obtain an authorization number. Flair Electronics will not accept any shipment whatsoever for which prior authorization has not been obtained.

Conditions to Void Warranty

This warranty applies only to defects in parts and workmanship relating to normal use. It does not cover:

- Damage incurred in shipping or handling;
- Damage caused by disaster such as fire, flood, wind earthquake or lightning;
- Damage due to causes beyond the control of Flair Electronics such as excessive voltage, mechanical shock or water damage;
- Damage caused by unauthorized attachment, alterations, modifications or foreign objects;
- Damage caused by peripherals (unless such peripherals were supplied by Flair Electronics);
- Defects caused by failure to provide a suitable installation environment for the products;
- Damage caused by use of the products for purposes other than those for which it was designed;
- Damage from improper maintenance;
- Damage arising out of any other abuse, mishandling or improper application of the products.

Items Not Covered by Warranty

In addition to the items which void the Warranty, the following items shall not be covered by Warranty: (i) freight cost to the repair center; (ii) products which are not identified with Flair Electronics product label and serial number; (iii) products disassembled or repaired in such a manner as to adversely affect the performance or prevent adequate inspection or testing to verify any warranty claim. Products not covered by this warranty, or otherwise out of warranty due to age, misuse, or damage shall be evaluated, and a repair estimate shall be provided. No repair work will be performed until a valid purchase order is received from the Customer and a Return Merchandise Authorization Number (RMA) is issued by Flair Electronics customer Service.

Flair Electronics' liability for failure to repair the product under this warranty after a reasonable number of attempts will be limited to a replacement of the product, as the exclusive remedy for breach of warranty. Under no circumstances shall Flair Electronics be liable for any special, incidental, or consequential damages based upon breach of warranty, breach of contract, negligence, strict liability, or any legal theory. Such damages include, but are not limited to, loss of profits, loss of the product or any associated equipment, cost of capital, cost of substitute or replacement equipment, facilities or services, downtime, purchaser's time, the claims of third parties, including customers, and injury to property. The laws of some jurisdictions limit or do not allow the disclaimer of consequential damages. If the laws of such a jurisdiction apply to any claim by or against Flair Electronics, the limitations and disclaimers contained here shall be to the greatest extent permitted by law. Some states do not allow the exclusion or limitation of incidental or consequential damages, so that the above may not apply to you.

Disclaimer of Warranties

This warranty contains the entire warranty and shall be in lieu of any and all other warranties, whether expressed or implied (including all implied warranties of merchantability or fitness for a particular purpose) and of all other obligations or liabilities on the part of Flair Electronics. Flair Electronics neither assumes responsibility for nor authorizes any other person purporting to act on its behalf to modify or change this warranty, nor to assume for it any other warranty or liability concerning this product.

Warning: Flair Electronics recommends that the entire system be completely tested on a regular basis. However, despite frequent testing, and due to, but not limited to, criminal tempering or electrical disruption, it is possible for this product to fail to perform as expected.

Out of Warranty Repairs

Flair Electronics will at its option repair or replace out-of-warranty products which are returned to its factory according to the following conditions. Anyone returning goods to Flair Electronics must first obtain an authorization number. Flair Electronics will not accept any shipment whatsoever for which prior authorization has not been obtained.

Products which Flair Electronics determines to be repairable will be repaired and returned. A set fee which Flair Electronics has predetermined and which may be revised from time to time, will be charged for each unit repaired.

Products which Flair Electronics determines not to be repairable will be replaced by the nearest equivalent product available at that time. The current market price of the replacement product will be charged for each replacement unit.



Flair Electronics

800 Palomares Ave
La Verne, Ca 91750

Phone (909) 568-0063
Fax (909) 568-0151

www.flairsecurity.com

Revision 0808D